

	A	B	C	D	E	SERIES 2 PANCAKE DRILL	
INCH	.350	1.042	3.152	.900	6.899	MAXIMUM RECOMMENDED DRILL DIAMETER	.250
MM	8.89	26.46	80.06	22.86	175.2		6.35 mm

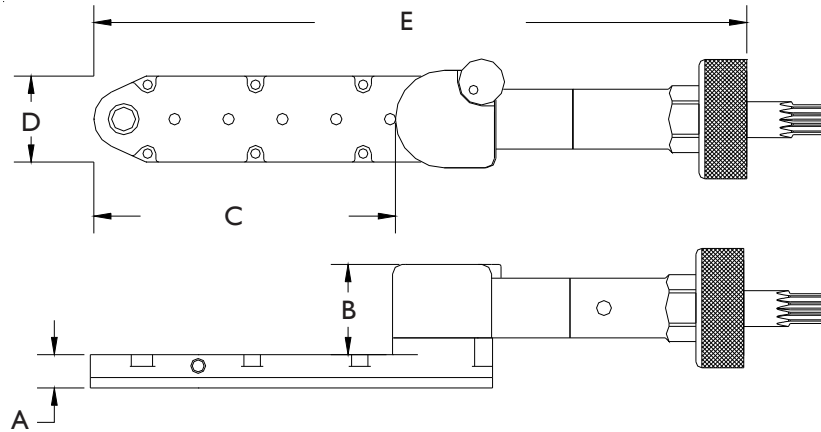

ALL BEARING INDEXABLE PANCAKE DRILLS



17680 ATTACHMENT ONLY
PART OF THE JIFFY MODULAR DRILL SYSTEM

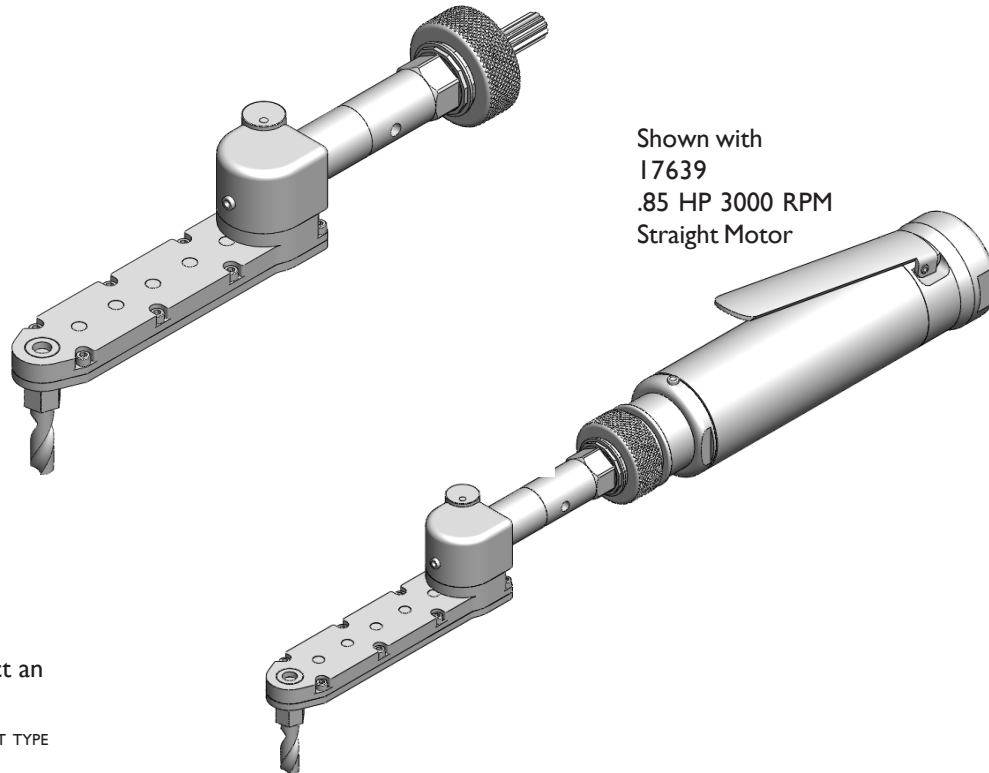

Shown with
17639
.85 HP 3000 RPM
Straight Motor

You must select an
internal thread

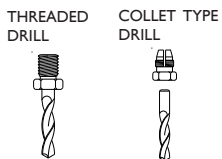

INTERNAL THREAD CODE	
1/4-28	A
10-32	C
9/32-40	E
5/16-24	F
7mm COLLET	D

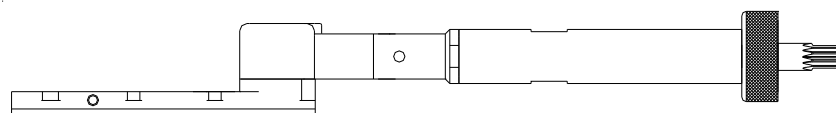

ATTACHMENT SHOWN WITH OPTIONAL
3.750" 95.25mm G EXTENSION ASSEMBLY

PHONE: 775 883 1072 FAX: 775 883 4857