

	A	B	C	D	E	SERIES 4 PANCAKE DRILL	
INCH	.500	1.15	6.36	1.12	10.43	MAXIMUM RECOMMENDED DRILL DIAMETER	.375
MM	12.7	29.2	161.5	28.4	264.9		9.52 mm

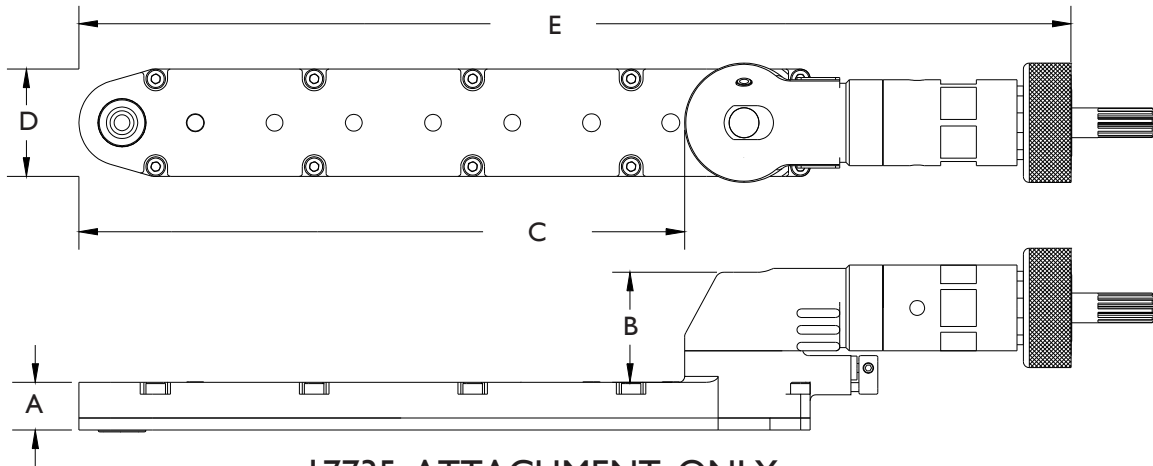

ALL BEARING INDEXABLE PANCAKE DRILLS



17735 ATTACHMENT ONLY
PART OF THE JIFFY MODULAR DRILL SYSTEM

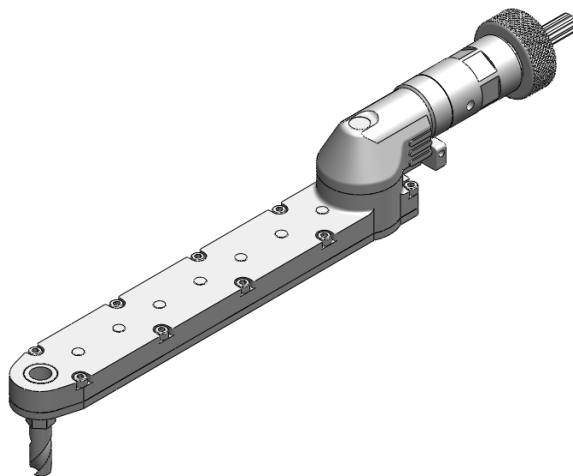

Shown with
17300
1.5 HP 6000 RPM
Straight Motor

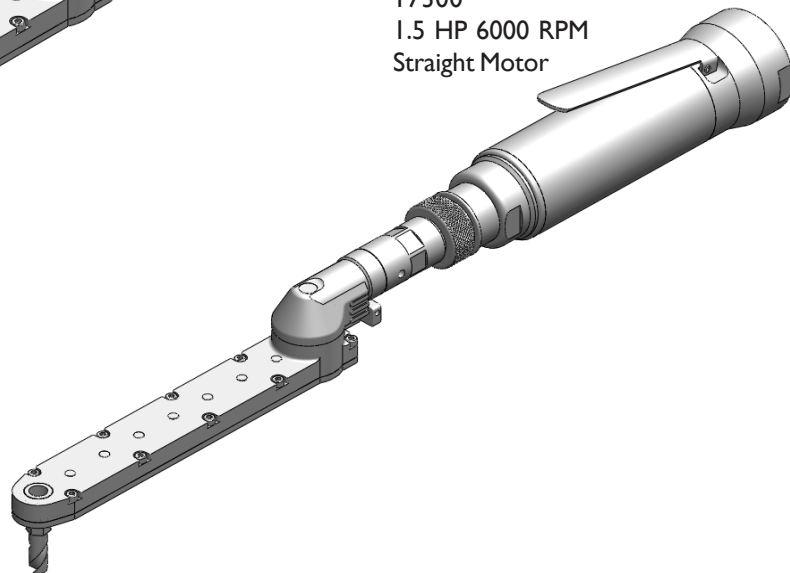

You must select an
internal thread

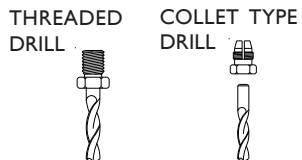

INTERNAL THREAD CODE	
1/4-28	A
9/32-40	E
5/16-24	F
3/8-24	Z
7mm COLLET	D
3/8-24 MALE	Y

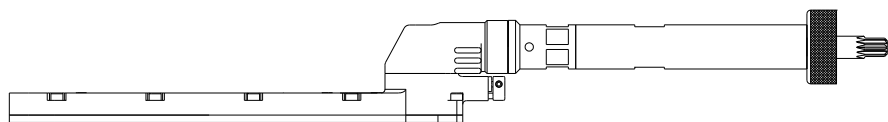

ATTACHMENT SHOWN WITH OPTIONAL
3.75" 95.25mm G EXTENSION ASSEMBLY

PHONE: 775 883 1072 FAX: 775 883 4857