

| | A | B | C | D | E | F | G | H | SERIES I 17 DEGREE DRILL | |
|------|------|-------|-------|------|------|------|------|------|--------------------------|------------|
| INCH | .250 | 4.48 | 5.35 | .90 | 1.02 | .327 | 3.93 | 1.10 | MAXIMUM RECOMMENDED | .1875 INCH |
| MM | 6.35 | 113.8 | 135.9 | 22.8 | 25.9 | 8.3 | 99.8 | 27.9 | DRILL DIAMETER | 4.76 mm |

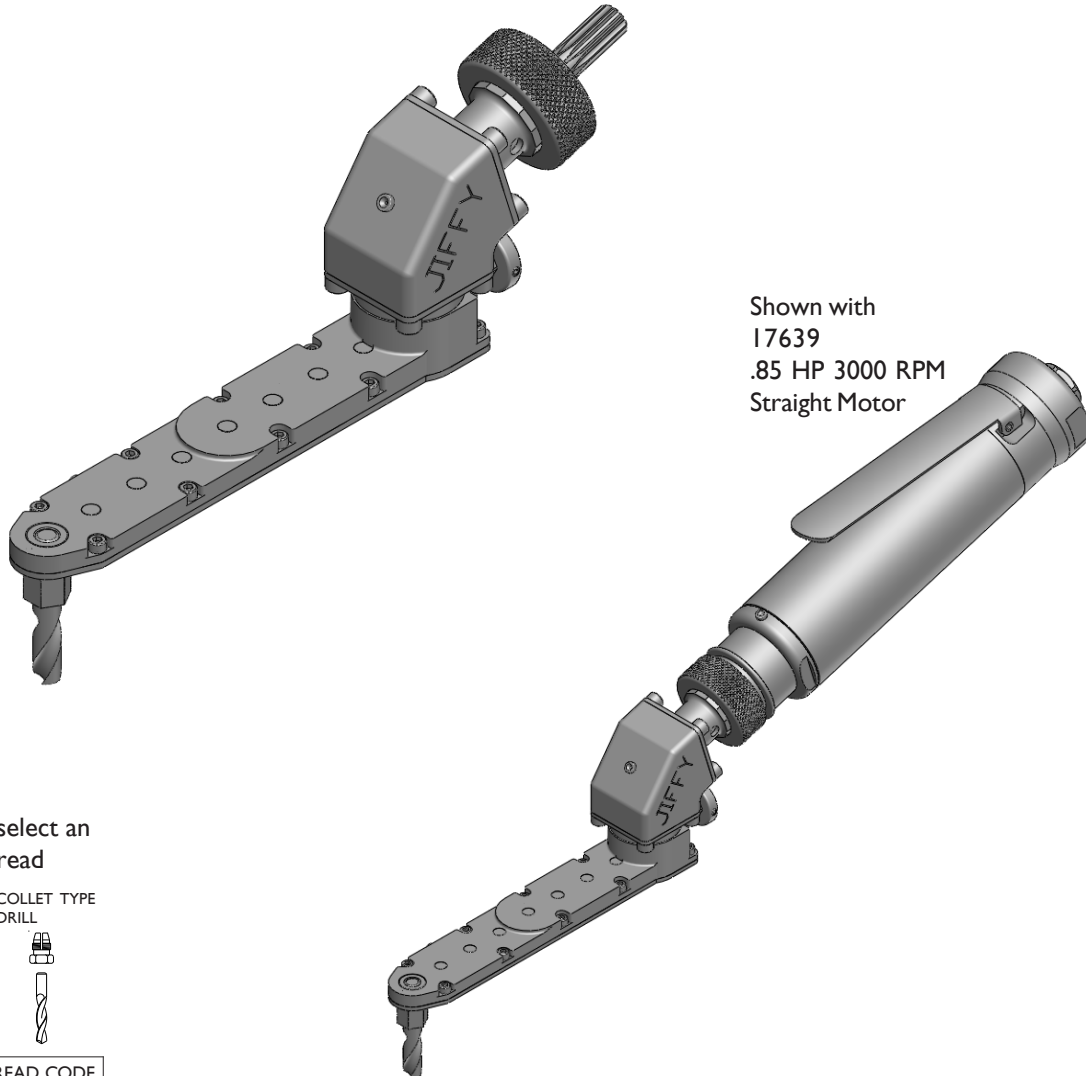

SERIES I INDEXABLE 17 DEGREE DRILLS

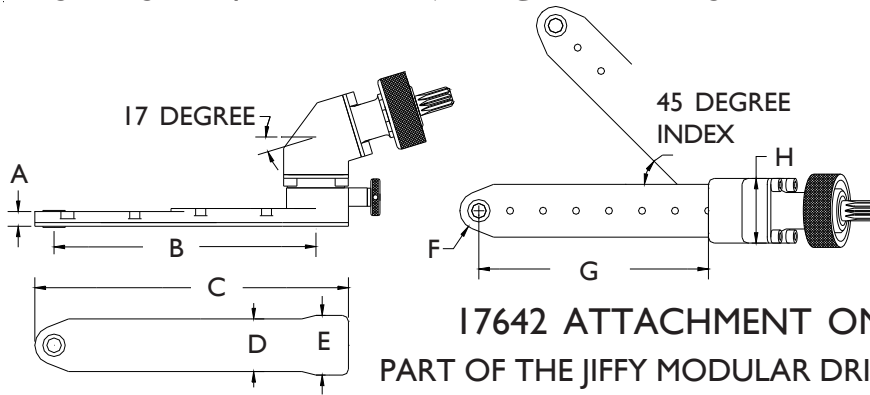

You must select an internal thread

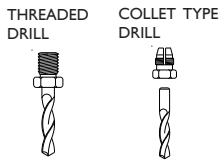

| INTERNAL THREAD CODE | |
|----------------------|---|
| 1/4-28 | A |
| 10-32 | C |
| 9/32-40 | E |
| 5/16-24 | F |
| 7mm COLLET | D |

PHONE: 775 883 1072 FAX: 775 883 4857