

	A	B	C	D	E	F	G	H	SERIES 2 17 DEGREE DRILL	
INCH	.350	2.23	3.1	.90	1.02	.327	1.68	1.10	MAXIMUM RECOMMENDED	.250 INCH
MM	8.89	56.6	78.7	22.8	25.9	8.3	42.6	27.9	DRILL DIAMETER	6.35 mm

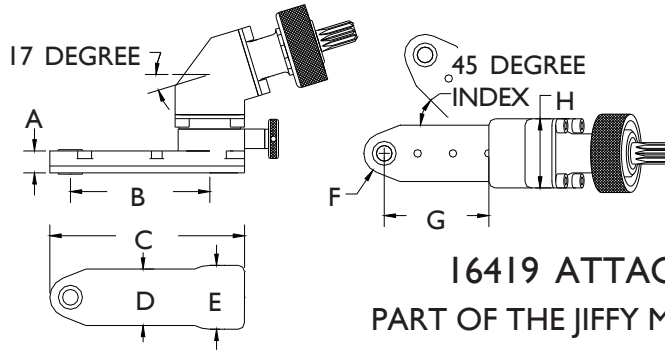

SERIES 2 INDEXABLE 17 DEGREE DRILLS



16419 ATTACHMENT ONLY
PART OF THE JIFFY MODULAR DRILL SYSTEM

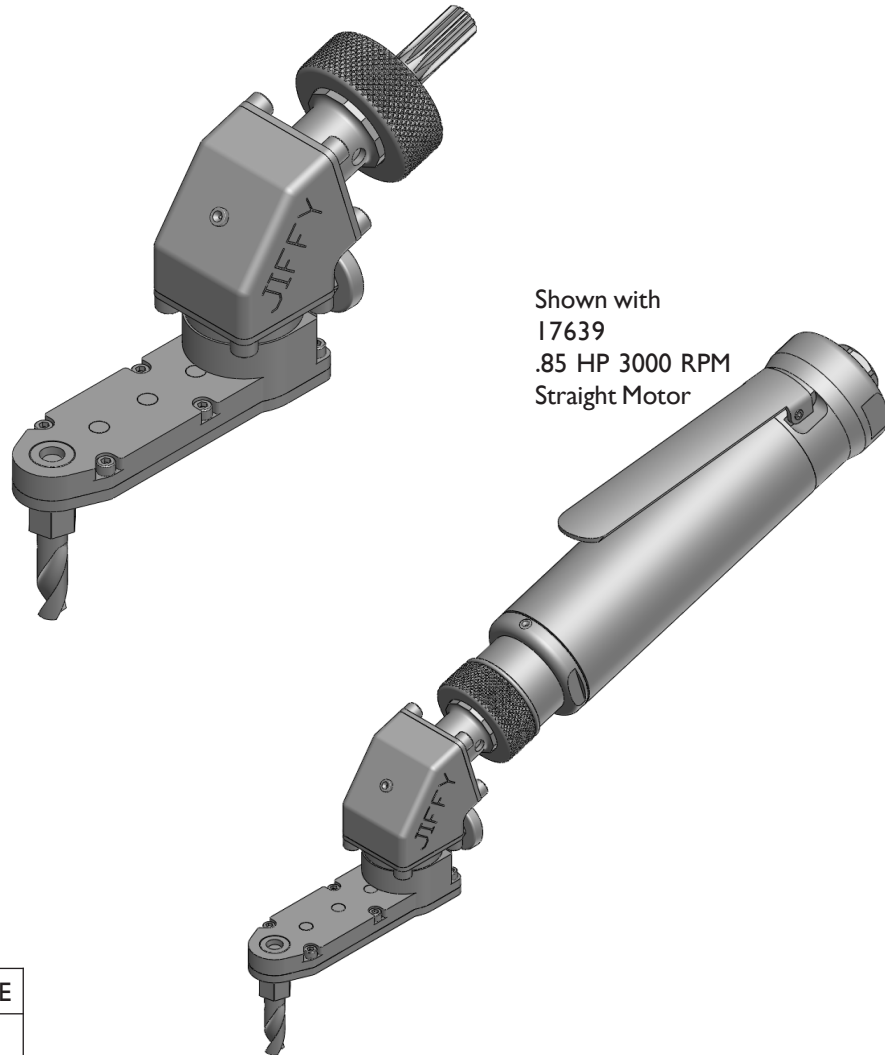

You must select an internal thread

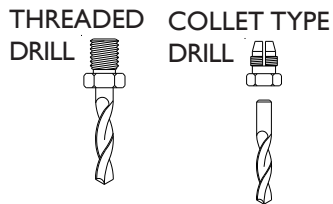

INTERNAL THREAD CODE	
1/4-28	A
10-32	C
9/32-40	E
5/16-24	F
7mm COLLET	D

PHONE: 1 775 883 1072 FAX: 1 775 883 4857