

	A	B	C	D	E	F	G	H	SERIES 2 17 DEGREE DRILL	
INCH	.350	3.35	4.22	.90	1.02	.327	2.80	1.10	MAXIMUM RECOMMENDED	.250 INCH
MM	8.89	85	107.1	22.8	25.9	8.3	71.1	27.9	DRILL DIAMETER	6.35 mm

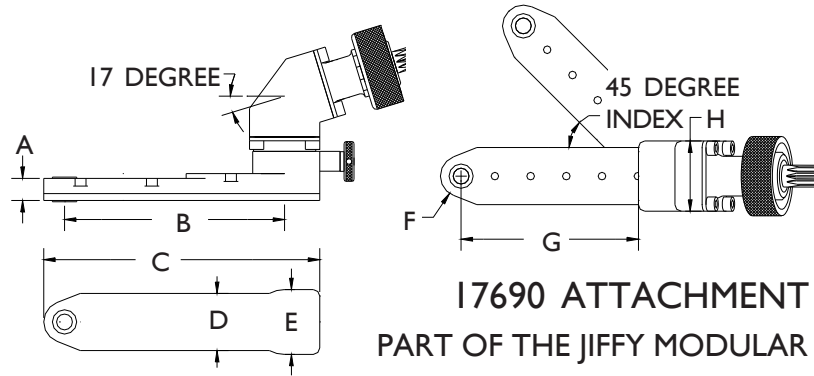

SERIES 2 INDEXABLE 17 DEGREE DRILLS



17690 ATTACHMENT ONLY
PART OF THE JIFFY MODULAR DRILL SYSTEM

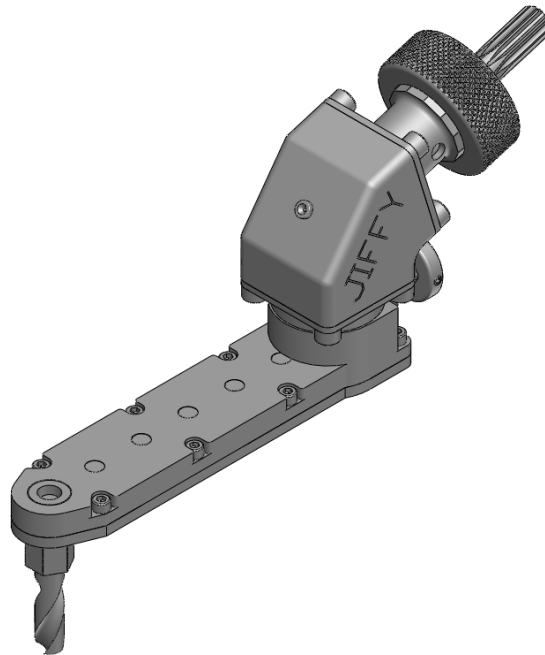

Shown with
17639
.85 HP 3000 RPM
Straight Motor

You must select an
internal thread

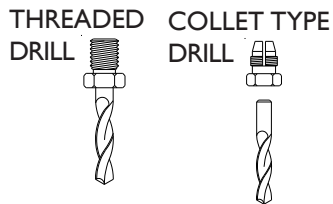

INTERNAL THREAD CODE	
1/4-28	A
10-32	C
9/32-40	E
5/16-24	F
7mm COLLET	D

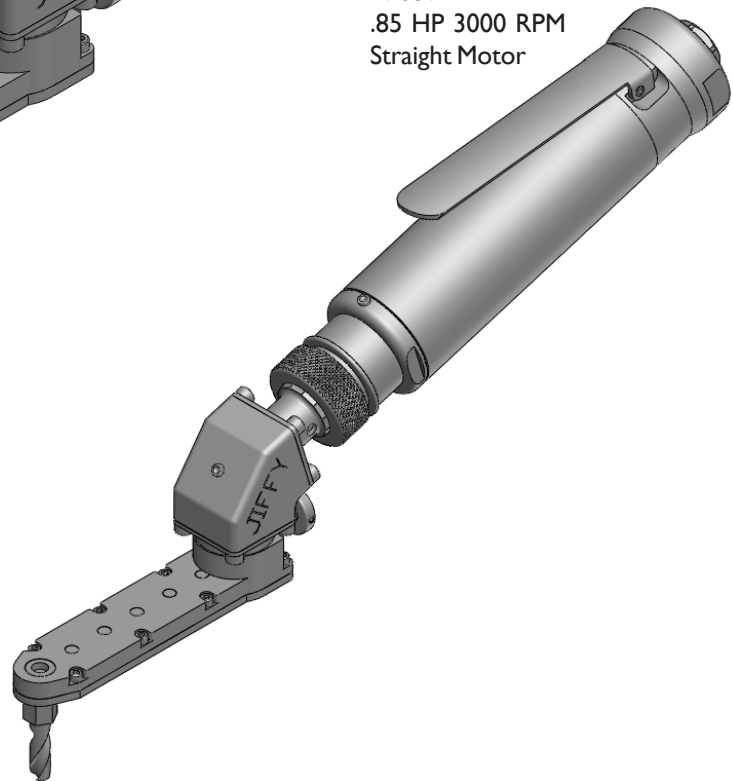

PHONE: 1 775 883 1072 FAX: 1 775 883 4857