

	A	B	C	D	E	F	G	H	SERIES 3 17 DEGREE DRILL	
INCH	.425	3.35	4.22	.90	1.02	.327	2.80	1.10	MAXIMUM RECOMMENDED DRILL DIAMETER	.312 INCH
MM	10.79	85	107.1	22.8	25.9	8.3	71.1	27.9		7.92 mm

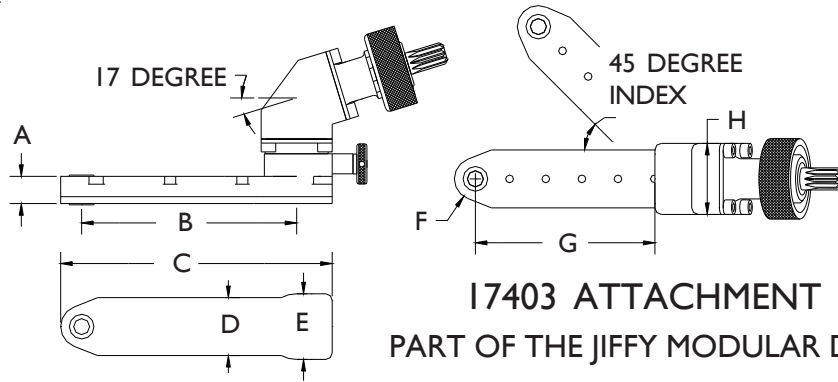

SERIES 3 INDEXABLE 17 DEGREE DRILLS



17403 ATTACHMENT ONLY
PART OF THE JIFFY MODULAR DRILL SYSTEM

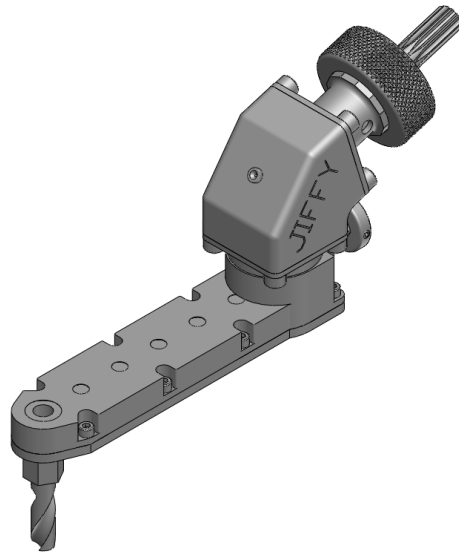

Shown with
17639
.85 HP 3000 RPM
Straight Motor

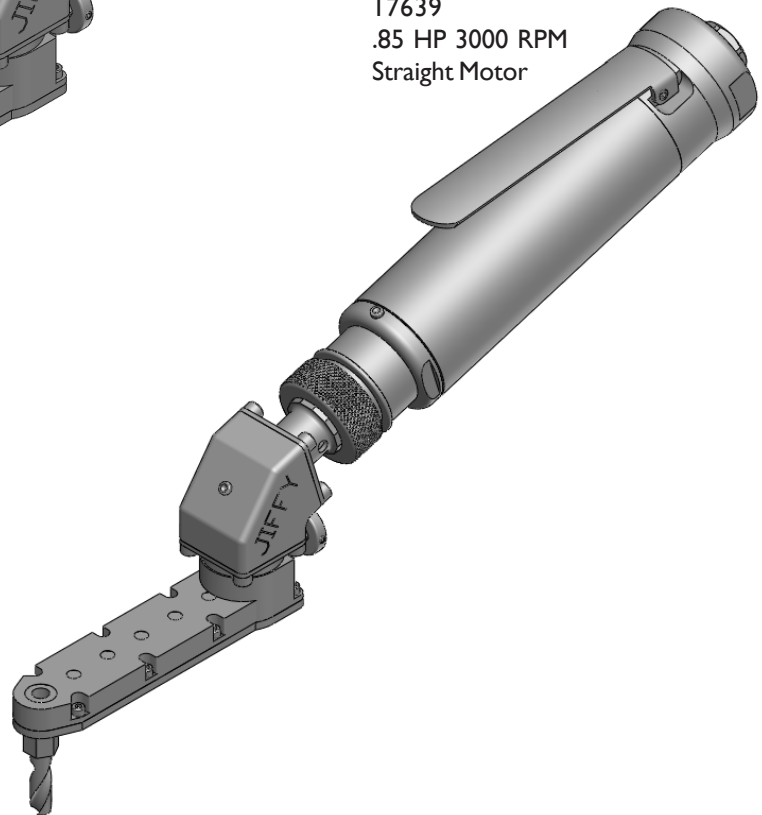

You must select an internal thread

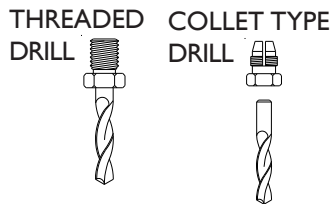

INTERNAL THREAD CODE	
1/4-28	A
10-32	C
9/32-40	E
5/16-24	F
7mm COLLET	D

PHONE: 1 775 883 1072 FAX: 1 775 883 4857