



# Model 6600 NUTPLATE DRILL



*Configurations and detailed drawings inside.*

# MODEL 6600

## NUTPLATE DRILL - FEATURE SHOWCASE



PHONE: 775-883-1072 FAX: 775-883-4857 WEB: [www.jiffyairtool.com](http://www.jiffyairtool.com)

The Model 6600 nutplate drill is a pneumatic hand tool specially made for precisely drilling & countersinking 2 holes simultaneously for the eventual attachment of nutplate fasteners. The tool uses a pneumatic piston, hydraulic feed control, & an expandable collet to clamp & feed the twin drill spindles through a work piece at a controlled & adjustable speed. The tool can be configured at 6000 or 600 RPM in a wide range of configurations to suit the tool to a variety of nutplate fasteners.

Please see "Model 6600" ordering information page for details on how to order.

SHOWN CONFIGURATION:  
6600-6000-DW437-1614-23-6

BROWN03152024

# Model 6600

## NUTPLATE DRILL - FEATURE SHOWCASE

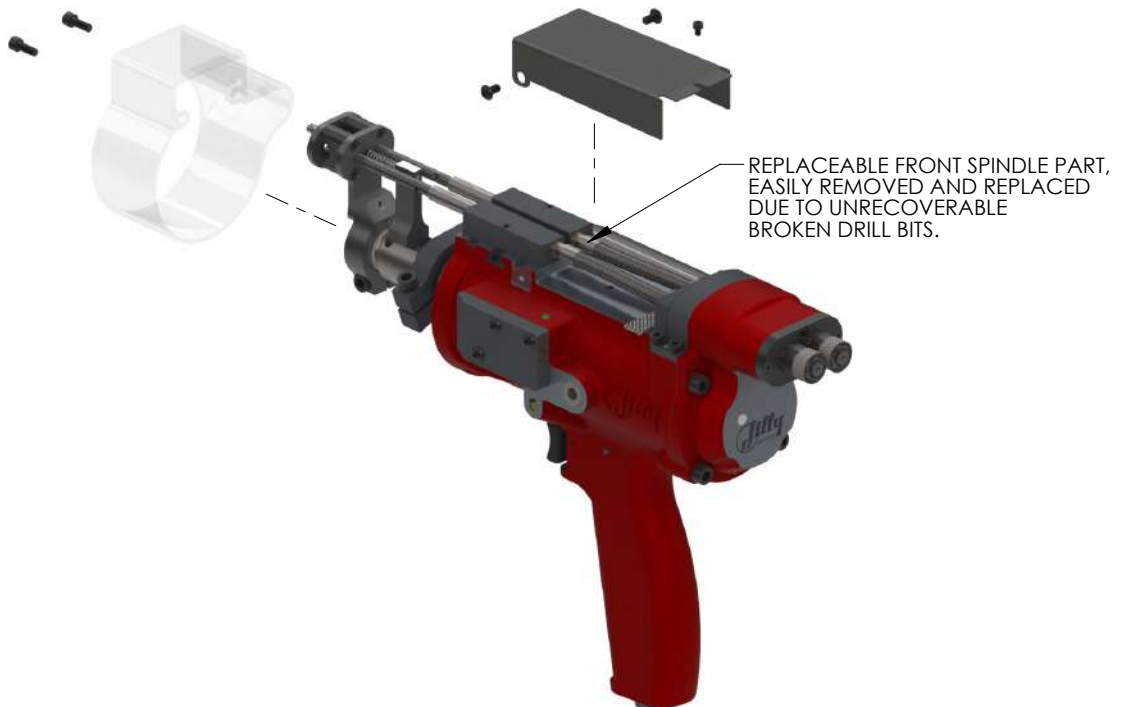
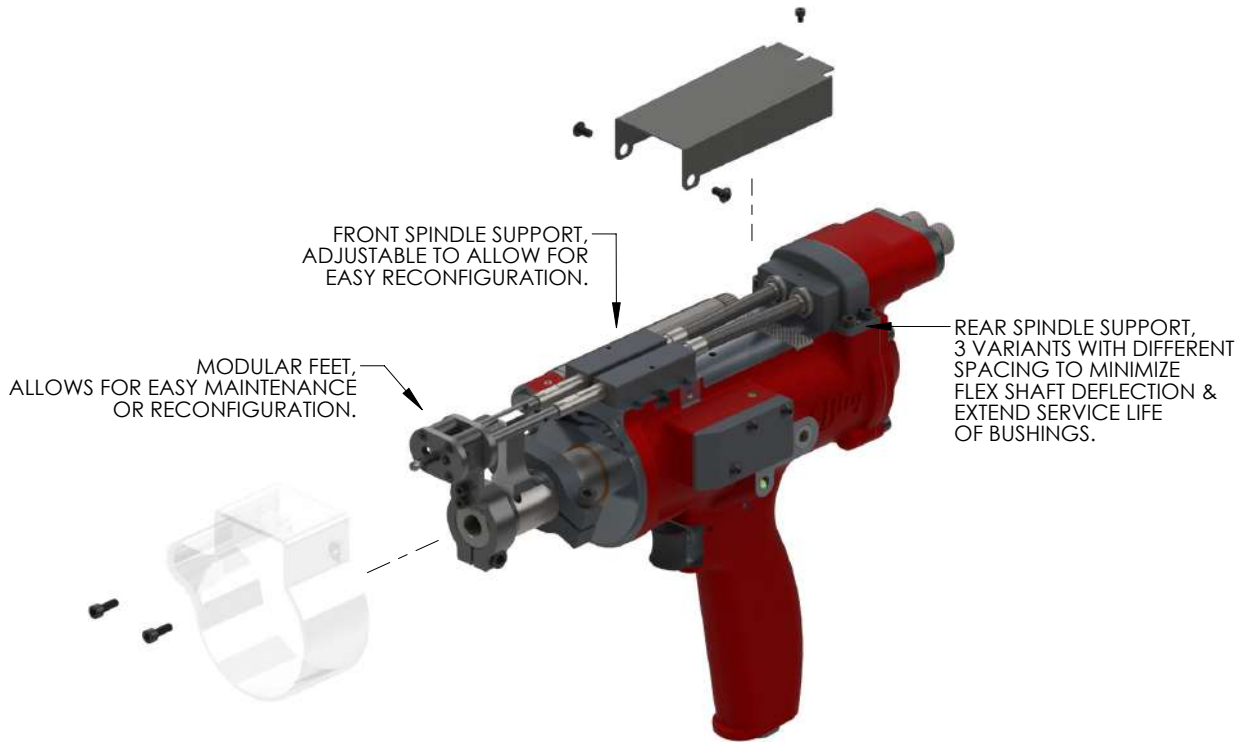

SHOWN CONFIGURATION:  
6600-6000-DW437-1614-23-6

BROWN03152024

PHONE: 775-883-1072 FAX: 775-883-4857 WEB: www.jiffyairtool.com

# MODEL 6600

## NUTPLATE DRILL - FEATURE SHOWCASE

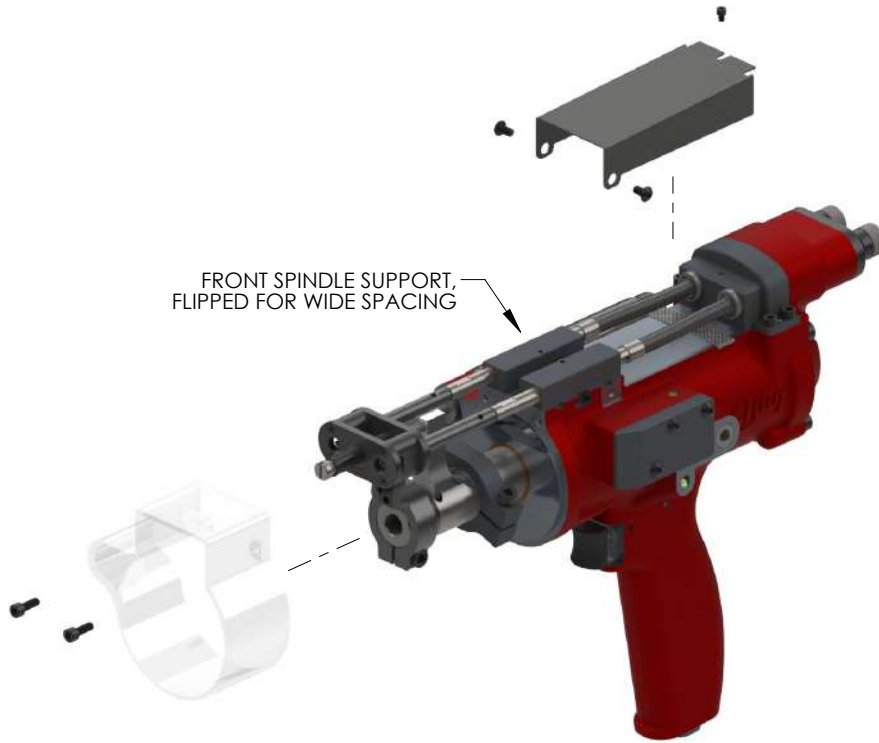

SHOWN CONFIGURATION:  
6600-6000-DW1000-2500-40-8

BROWN03152024

PHONE: 775-883-1072 FAX: 775-883-4857 WEB: [www.jiffyairtool.com](http://www.jiffyairtool.com)